

## Self-Tapping Screws for Thermoplastics

- Dimensions for screws and screw holes
- Recommendations for Durethan® and Pocan®

Detachable joints for plastics parts which are produced through the use of self-tapping screws have been successfully employed for a long time, since they are both reliable and inexpensive. The pull-out strength of self-tapping screws is similar to that of screw connections achieved with molded-in threaded metal inserts.

### The quality of a screw connection

The following factors have a key influence on the quality of a screw connection:

- Geometry of the screw and the screw boss
- Screw-in torques
- Torque cut-off
- Insertion speed

### Geometry of the screw and the screw boss

#### 1. Screws

Geometries with the following characteristics have proved suitable:

- sharp-angle thread  $< 40^\circ$
- small core diameter  
 $< 0.65 \times D$  (for PA GF  $< 0.8 \times D$ )
- high thread pitches  
 $> 0.35 \times D$  (for PA GF  $> 0.25 \times D$ )
- tight manufacturing tolerances

Countersunk-head screws are not suitable for thermoplastics on account of their expanding effect.

#### 1.1 Screws with a cutting notch

These screws cut the thread and are suitable for once-only assembly or for connections that only need to be disconnected and re-assembled a few times. They are characterized by a low insertion torque  $M_i$  and a relatively high stripping torque  $M_s$ ,

which means that their  $M_s/M_i$  ratio is particularly favorable.

The drawback to this type of screw is that repeated assembly is only possible if the screw is carefully inserted into the original thread once again (by hand). Problems can thus be encountered in respect of compliance with DIN 57700/VDE 0700.

#### 1.2 Screws without a cutting notch

All the screws of the design shown in Figure 1 are suitable for thermoplastics, providing that the dimensioning rules for the screw boss are observed (Figure 2). These will then generally fulfill the DIN/VDE requirements as well.

Core diameter $D_c$ (mm)	$< 0.65 \times D$	
Thread lead $P$ (mm)	$0.35 \times D \dots 0.55 \times D$	
Thread angle $\alpha$	$< 40^\circ$	
<p><math>D</math> = thread diameter The nominal diameter may deviate from the actual outside diameter since different tolerances are employed for different screw types.</p>		

Figure 1 Screw geometry

#### Advice on less suitable screw geometries

In isolated cases it may be necessary, for logistical reasons, to have recourse to less suitable screw geometries, such as sheet metal screws, which do not comply with the specifications in Figure 1. Since this can lead to increased strain on the screw boss, it is necessary for the geometry of the boss to be modified in the appropriate manner. Figure 2 shows the design dimensions (in brackets) that have proved successful. In view of the considerably

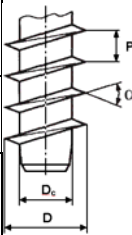

higher loads acting on the plastic, tests should be conducted for purposes of establishing the serviceability of the connection.

## 2. Boss geometries

In the case of a standard screw connection, the boss geometry should comply with the recommendations given in Figure 2. The hole diameters should display a tight tolerance in order to guarantee a consistent quality.

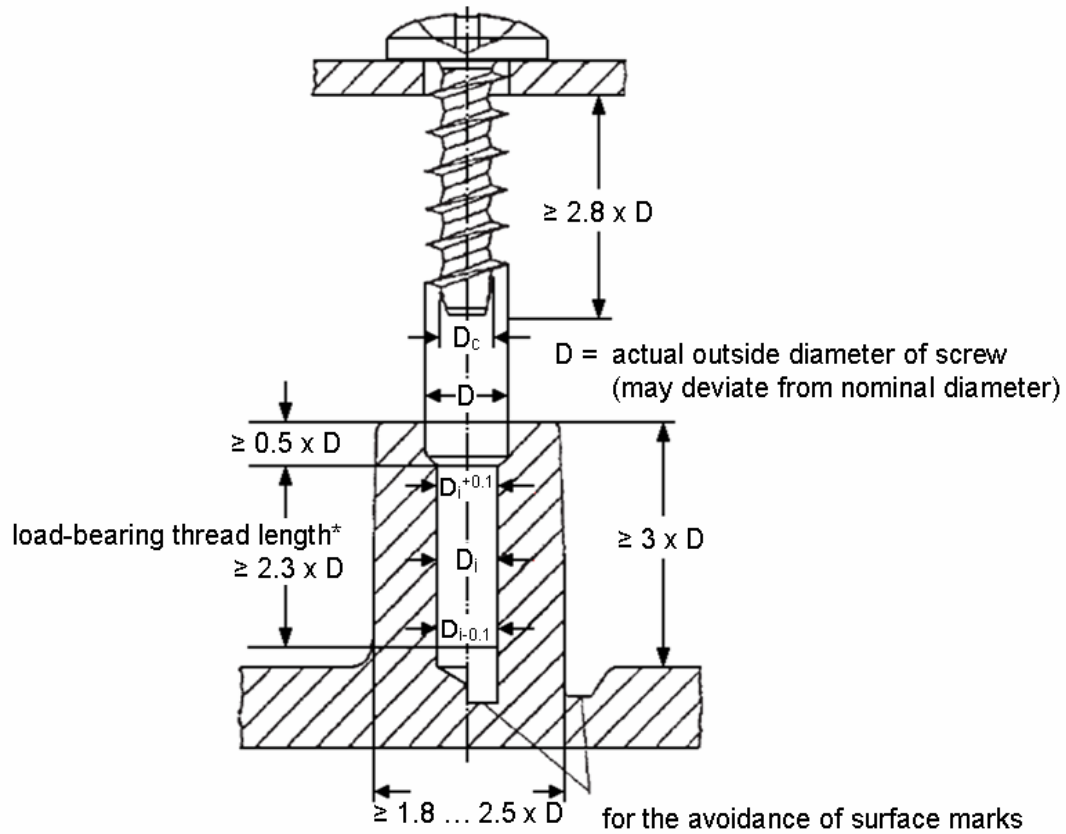

\* The greater the screw-in depth, the better the compliance with VDE regulations  
 Recommended length of engagement  $\geq 3 \times D$  in order to reliably fulfill VDE regulations



Self-Tapping Screws without Cutting Notches Recommended dimensions for screw holes (valid for D = 2.9 to 5.1 mm)	screw geometry as per Figure 1 valid	
LANXESS products	Non-reinforced	Glass fiber reinforced
Pocan (non-reinforced)	$Di = 0.85 \times D$	$Di = 0.87 \times D$
Durethan A (glass fiber reinforced, freshly molded)		$Di = 0.90 \times D$
Durethan A (glass fiber reinforced, conditioned)		$Di = 0.87 \times D$
Durethan B (non-reinforced, freshly molded)	$Di = 0.86 \times D$	$Di = 0.88 \times D$
Durethan B (non-reinforced, conditioned)	$Di = 0.82 \times D$	$Di = 0.86 \times D$

Figure 2 Recommended dimensions for screw holes

If the relatively high tightening torque means that the connection fails to comply with the requirement for assembly and disconnection ten times over, as specified in DIN 57 700/VDE 0700, then the remedy frequently adopted in practice is to reduce the diameter of the hole.

The best way to reliably absorb higher tightening torques is to increase the screw-in depth. This leads to just a slight increase in the insertion torque but raises the stripping torque quite considerably and hence also serves to increase the permitted tightening torque.

### Screw-in torques

The insertion torque  $M_i$  denotes the maximum torque that occurs as the screw is being inserted, prior to the screw head coming into contact with the surface against which it will rest. The torque employed to tighten the screw is the tightening torque,  $M_t$ . This should be at least 1.2 times the insertion torque, but should not exceed 0.5 times the stripping torque  $M_s$ , required to strip the thread (Figure 3). The insertion torque and stripping torque should be determined experimentally. The higher the ratio of  $M_s$  to  $M_i$ , the more reliable the screw connection will be.

Taking Durethan BKV 60 H 2.0 as an example, the following graph shows how the torque is influenced by the core diameter of the screw boss.

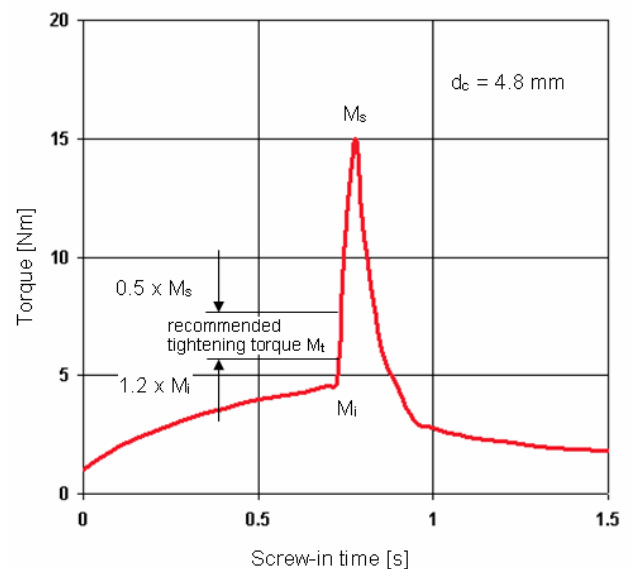

Figure 3 Screw-in torques

$M_i$  = insertion torque,  $M_t$  = tightening torque,  
 $M_s$  = stripping torque

Using a self-tapping screw of the type EJOT Delta PT WN 5451, 60 x 25 screw-in and pull-out tests (static) were carried out on Durethan DP BKV 60 H2.0 EF, a new product development with 60 % glass fiber reinforcement and extremely good flowability. The tests with this 6 mm (nominal diameter) screw were conducted on a uniform, injection molded boss with core hole diameters of 4.8 – 5.0 – 5.2 and 5.4 mm.



The optimum core diameter was found to be 5.2 mm, because this gave the maximum difference between the screw-in force and the stripping torque and thus maximum reliability for the connection being tested.

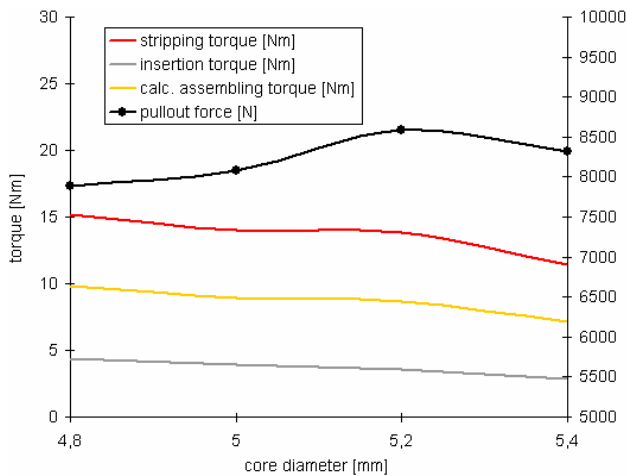

Figure 4 Screw-in test on Durethan DP BKV 60 H2.0 EF (conditioned for 3 weeks at 70 °C, 65 % r.h. Ejot Delta PT screw WN 5451 60 x 25 (nominal diameter 6 mm) Screw spindle speed 550 min<sup>-1</sup>

### Torque cut-off

When self-tapping screws are employed, the connection is already frequently damaged at the assembly stage on account of excessively high tightening torques being employed.

The most frequent reasons for this are:

- The kinetic energy of rotating nut runner masses that cannot be braked quickly enough, on account of the inertia of the mass (this frequently occurs at high speeds and with small screw diameters)
- An incorrectly estimated or unknown stripping torque
- Excessively small screw-in depths

### Insertion speed

With the right insertion speeds, sufficient frictional heat will develop to slightly melt the plastic in the

region of the thread flanks. This will then make it easier for the thread flanks to penetrate the plastic, thereby reducing the tangential stress and increasing the stripping torque at the same time.

If excessive frictional heat prevails (on account of high nut runner speeds), the area of plastic that melts will become greater while the stripping torque decreases and the quality of the screw connection also deteriorates (Figure 5).

With only a low level of frictional heat (low nut runner speed, manual screw insertion), high tangential stresses will develop in the screw boss, leading to a poorer-quality screw connection.

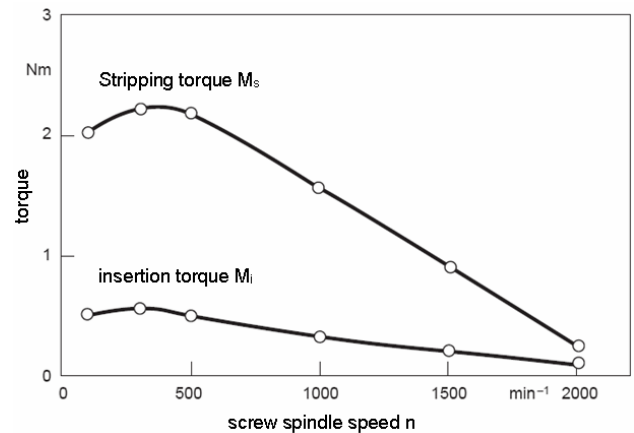

Figure 5 Example torques versus spindle speed

Since the frictional heat is additionally influenced by the screw-in depth and the surface characteristics of the screws employed, it is advisable to conduct a number of application-based tests in order to establish the optimum nut runner speed.

Screw circumferential velocities of between 3 and 6 m/min have proved successful for molded parts made of LANXESS thermoplastics. For screws with a nominal diameter of 4 mm, this corresponds to a nut runner speed of 250 to 500 rpm

NB: The no-load speed specified for standard commercial nut runner units is frequently much higher than the speed actually attained under load.



---

Durethan® and Pocan® are registered trade names of LANXESS Deutschland GmbH

**Disclaimer for sales products**

This information and our technical advice - whether verbal, in writing or by way of trials - are given in good faith but without warranty, and this also applies where proprietary rights of third parties are involved. Our advice does not release you from the obligation to verify the information currently provided - especially that contained in our safety data and technical information sheets - and to test our products as to their suitability for the intended processes and uses. The application, use and processing of our products and the products manufactured by you on the basis of our technical advice are beyond our control and, therefore, entirely your own responsibility. Our products are sold and our advisory service is given in accordance with the current version of our General Conditions of Sale and Delivery.

**Disclaimer for developmental products**

This is a trial product. Further information, including amended or supplementary data on hazards associated with its use, may be compiled in the future. For this reason no assurances are given as to type conformity, processability, long term performance characteristics or other production or application parameters. Therefore, the purchaser / user uses the product entirely at his own risk without having been given any warranty or guarantee and agrees that the supplier shall not be liable for any damage, of whatever nature, arising out of such use. Commercialization and continued supply of this material are not assured. Its supply may be discontinued at any time.

